



**NEW**



## 44 Series LED Surface Mount Dome Lamp

### FEATURES & BENEFITS

- Surface mount design eliminates the need for large hole cutouts in trailer ceiling
- White housing design blends well with refrigerated trailer interiors
- Available with integrated on/off switch as well as externally controlled version
- Lens design recesses lens into housing, to prevent damage from impact
- Not affected by cold temperatures, providing flicker-free lighting with a faster start-up time
- Ideal for refrigerated vehicles or those operating in cold weather
- Solid-state LED design is impervious to damage from shock and vibration
- Retrofit or replacement is quick and easy
- LED's are fully encapsulated in epoxy to prevent damage caused by moisture and corrosives
- Recommend 3 #10 machine screws for mounting, with torque of 15-18 in-lbs.

### TECHNICAL SPECIFICATIONS

#### Material:

- Polycarbonate lens and housing
- 18 gauge blunt cut wire

#### Light Source:

- 6 Light Emitting Diodes (LED's)
- Operating Voltage: 13.5v
- Current draw: 0.5a

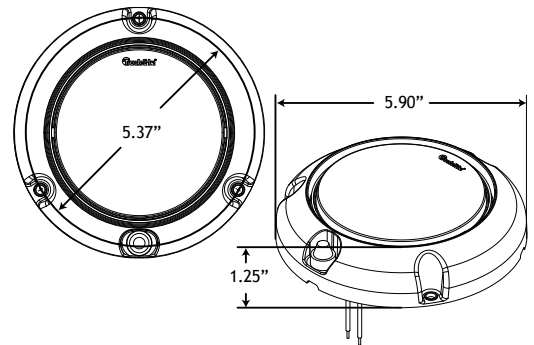

### PART NUMBERS

Part No.	Description	Ctn. Qty.
44438C	Surface Mount Dome Lamp, w/ Switch	1
44439C	Surface Mount Dome Lamp	1

