

36 Series Flex-Lite w/Non-Winged Housing Clearance/Marker Lights



FEATURES & BENEFITS

- Provides a clearance/marker solution that requires no mounting brackets or installation screws
- Lamps adhere directly to application surface through the use of heavy-duty adhesive backing
- Easy-to-install peel-off liner
- Hard-wired lamp design is easily retrofittable
- Rear exit wire version requires a 3/8" mounting hole, and self-seals hole upon installation
- Side mount options can be mounted without any mounting holes
- LEDs draw much less current, allowing more power for other vehicle requirements
- Electronics are completely sealed in epoxy to resist damage caused by moisture and corrosion
- Reduces lighting costs caused by physical damage and heat entrapment

TECHNICAL SPECIFICATIONS

Materials:

- Polycarbonate lens
- Over-molded hot-melt housing/substrate
- 20 gauge wire

Light Source:

- Light emitting diodes (LEDs)
- Designed at 12.8v, .03 amp (red), .05 amp (yellow)

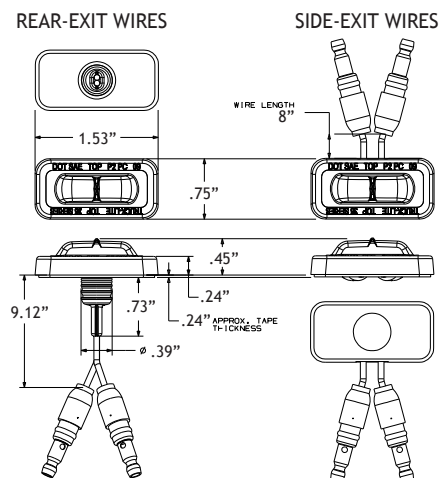

PART NUMBERS

Adhesive Mount with Non-winged Housing:
FOR CORNER MOUNTING APPLICATIONS

Part No.	Description	Std Ctn. Qty
36105R	Red Lamp, Side Exit Wires	1
36105Y	Yellow Lamp, Side Exit Wires	1
36115R	Red Lamp, Rear Exit Wires	1
36115Y	Yellow Lamp, Rear Exit Wires	1