

36 Series Flex-Lite w/Winged Housing Clearance/Marker Lights



FEATURES & BENEFITS

- Winged housing provides option for mounting around corners on a radius
- Provides a clearance/marker solution that requires no mounting brackets or installation screws
- Lamps adhere directly to application surface through the use of heavy-duty adhesive backing
- Easy-to-install peel-off liner
- Hard-wired lamp design is easily retrofittable
- Rear exit wire version requires a 3/8" mounting hole, and self-seals hole upon installation
- Side mount options can be mounted without any mounting holes
- LEDs draw much less current, allowing more power for other vehicle requirements
- Electronics are completely sealed in epoxy to resist damage caused by moisture and corrosion
- Reduces lighting costs caused by physical damage and heat entrapment

TECHNICAL SPECIFICATIONS

Materials:

- Polycarbonate lens
- Over-molded hot-melt housing/substrate
- 20 gauge wire

Light Source:

- Light emitting diodes (LEDs)
- Designed at 12.8v, .03 amp (red), .05 amp (yellow)

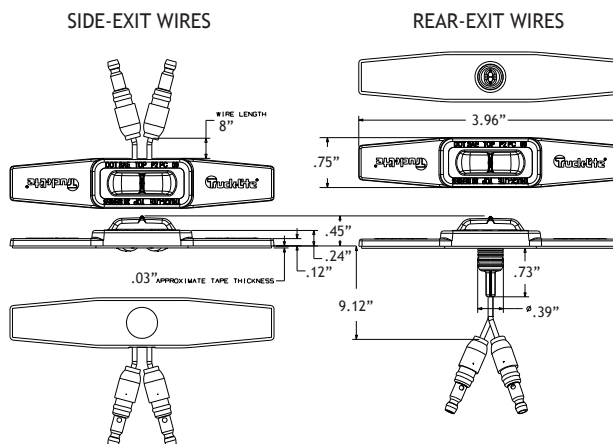

PART NUMBERS

Adhesive Mount with Winged Housing:
FOR CORNER MOUNTING APPLICATIONS

| Part No. | Description | Std Ctn. Qty |
|----------|------------------------------|--------------|
| 36100R | Red Lamp, Side Exit Wires | 1 |
| 36100Y | Yellow Lamp, Side Exit Wires | 1 |
| 36110R | Red Lamp, Rear Exit Wires | 1 |
| 36110Y | Yellow Lamp, Rear Exit Wires | 1 |